



# Friul Co. M51 Sheeter User & Installation Manual



## INTRODUCTION

Congratulations on selecting a product that was designed and constructed with advanced technology. We recommend that you read through this manual fully before using this appliance. It contains very important information and instructions regarding installation, use and maintenance. The product you have purchased was carefully designed and constructed and has been subjected to strict inspection tests in our laboratories. Installation must be done according to the instructions by professionally qualified personnel who are able to take on the responsibility for the installation to ensure the best conditions for operation and safety.

## TECHNICAL SUPPORT

The manufacturer is able to solve any technical problem concerning use and maintenance. In the remote possibility of poor operation or a repair, only use qualified personnel or contact our authorized service centers.

## INITIAL INSTRUCTIONS

**ATTENTION!** Failure to comply with what is described in this handbook could jeopardize safety and void warranty.

The manual must be kept carefully and in an accessible location, it must also always accompany the product during its life. Before installation and use, this manual must be read carefully and the instructions it contains must be followed scrupulously.

The manufacturer declines all civil and criminal liability for damage to people, property or animals deriving from the failure to observe current safety regulations, failure to respect the contents of this manual and from any printing or transcription errors.

It also declares that it reserves the right to make any changes to the product that it considers appropriate without the obligation to provide notice. Before handling, installing or using the product, verify the suitability of the room where it will be located.

Make sure that all safety measures have been taken in order to avoid any accidents.

Note: Pizza Equipment Professionals has provided this manual as an English only copy of the Friul Co. Pizza Sprint manual provided by the manufacturer. Words and descriptions may have been altered.





# M33 / M51 Dough Sheeter

The Friul Co. Dough Sheeters are a completely revolutionary way of making a perfectly shaped base for a pizza.

The sheeters have a parallel dough roller that requires only a single pass to roll a pizza base (See Chart Below for Dimensions).

The M33 and M51 are heavy duty machines made of stainless steel with a chain driven running gear, and Delrin (synthetic) non-stick rollers. Built in safety features include a dough chute, guards and micro-switch, making these the safest Dough Sheeters available on the market.



**M51**



- ETL and NSF approved.
- Durable Stainless Steel
- Safety Mechanisms
- Production Capacity of up to 700 bases per hour
- Non-stick rollers
- Adjustable portion controls
- Sleek Design

Dimensions & Power Specs	M33	M51
Power	370 Watts, 6.5 Amps	750 Watts, 10.6 Amps
Current	120v - 60Hz - 1 Phase	120v - 60Hz - 1phase
Net Weight	86 Lbs.	194 Lbs.
Shipping Weight	108 Lbs.	218 Lbs.
Shipping Dimensions	24" x 22" x 32"	25" x 23" x 35"
Machine Dimensions	16" x 19" x 28.5"	25" x 28" x 35"
Portion Weight	3.5 - 12.3 oz. / 4" to 13" Dia.	7 to 35 oz. / 10" to 20" Dia.
Hourly Production	700 bases	700 bases



**M33**



## A) USE AND MAINTENANCE

### 1. EMPLOYMENT OF THE MACHINE

The dough sheeter has been designed and manufactured to laminate (at room temperature) the dough for pizza and bread. The dough is flattened between two pairs of rolls.

The lamination which is similar to the one by hand with a rolling pin does not alter the dough.

**WARNING:** do not introduce into the machine frozen, half frozen dough or other products which are not foreseen in these instructions.

### 2. WORK SPACE

Place 55cm from the edge of surface to allow workable space.

The machine has to be placed on a horizontal working plan and be used by single person.

**WARNING:** the funnel 424 (see page 7) must always be placed on the machine and it is forbidden to work with the machine without this part. **NOTE: through the funnel 424 you can reach with hands a very dangerous part of the machine, i.e. the upper rolls.**

We remind you neither to introduce your hands into the funnel nor to use resistant gloves which can be seized by rolls while working

### 3. STARTING UP

The machine is provided with a one phase motor.

Before connecting the machine, be sure that the tension and the frequency correspond to those indicated on the machine data plate and that the intake is earthed and properly protected from overloading.

**N.B. The operation circuit has IP 55 protection grade.**

### 4. USE

4.1 See page 7

4.2 Dust your hand with flour, take the yeasted dough ball weighing from approx. 150 up to 1000 grams and cover it **abundantly** with flour.

4.3 Start the machine with the pushbutton 429

4.4 Introduce the dough (**abundantly covered with flour**) into the upper opening 424

4.5 After about one second, the dough will come out from the lower rolls: **Guide the dough out without pulling it.**

### 5. TRANSPORTATION

The machine is packed into a cardboard box which is then put in a wooden pallet and fixed with hoop-iron. Each cardboard box contains a complete machine.

For weights and sizes of the packages see page 3



## 6. INSTALATION

6.1 Place the machine far from any heat source, the temperature around the machine should never be higher than 55°C.

## 7. DISASSEMBLING

7.1 Take off the funnel 424 after having switched off the machine with the pushbutton 429 (the funnel is fixed to the machine with two knobs 634)

7.2 Take away the lower protection 428 after having unscrewed the two knobs 634

7.3 Take out the spring 413 from the lower dough scraper in order to take out both dough scrapers for daily cleaning.

7.4 Take out the central plate 414 pulling it slightly upwards and toward the user.

## 8. REGULATION

The best regulation for the machine Pizza Sheeter can be obtained gradually since it can be suitable for any type of dough. The machine is provided with new patented transfer device 415 (balance).

For instance: for portions weighing approx. 160-240 grams, set with lever 410 the upper rolls on about position 4 and with lever 410 the lower rolls on about position 4.

For lighter portions, close the upper and lower rolls by position at a time. For heavier portions, open the upper and lower rolls by one position at a time. We just remind you that the opening of the lower rolls must correspond to the final required thickness.

Should the dough not come out round:

- 1) the opening of the upper rolls and of the lower rolls have not been adjusted properly.
- 2) the dough did not have a roughly round shape when introduced into the funnel.
- 3) the dough has been pulled out and not accompanied when coming out of the lower rolls.

## 9. MAINTENANCE

9.1 To keep the machine well-functioning, you just need to dry-clean daily all dough remaining on the rolls using a brush if possible. The parts which can be disassembled (dough scraper, plate, funnel) must be washed instead with liquid detergent for dishes taking care then to rinse them in cold water. As far as the housing of the machine is concerned, we remind you to clean it neither with hypochlorite-based solutions nor with abrasive detergents since they could damage the external parts of the machine.

The machine does not need any peculiar lubrications.

**WARNING: do not wash the machine with water jets for safe working. Do not clean the machine while the rolls are moving and most of all do not put your hands into the rolls to clean them.**



## 9.2 REPAIRS

For repairs, control or replacement of damage parts, we suggest you to apply to the retailer or directly to the manufacturer or to replace the damage parts with equivalent materials especially as far as safety is concerned:

- electrical cable with plug (2 phase + earth)
- switch (pushing-buttons)

Before any mechanical or electrical maintenance, switch the machine OFF and pull out the plug.

WARNING: the repairs are to be carried out by qualified people. Periodically check the good conditions of the machine, of the cable and of its plug.

## B) ELECTRICAL SCHEME (see diagram on pg 9)

## C) LOUDNESS

Estimated equivalent continuous level of acoustic pressure produced by the machine while working and under load is under 70 decibels (A) and that the maximum estimated instantaneous value of acoustic pressure (C) is under 130 decibels.

## D) ESSENTIAL REQUIREMENTS

1. All the machines have been designed and manufactured strictly in compliance with the current national and international norms and particularity:

1.1.89/392 ECC Directive and more precisely the enclosure 1 points 1 and 2: essential safety and sanitary requirements

1.2 The regulations of the United States of America and more particularly the NSF Norms.

1.3 We bring to your attention that all the materials which are not of stainless steel and which get into contact with food have been approved and their use has been authorized by the National Sanitary Services and by the American NSF laboratories.

2. It must be underlined that once assembled and before being packed, all the machines undergo a checking test carried out by an electronical equipment called "CHECKING DESK" which controls:

2.1 Earth continuity

2.2 Dielectrical rigidity

2.3 Insulation

2.4 Functioning of the machine without loading it, recording: the absorbed power, the applied tension, absorbed amperes.



# M51

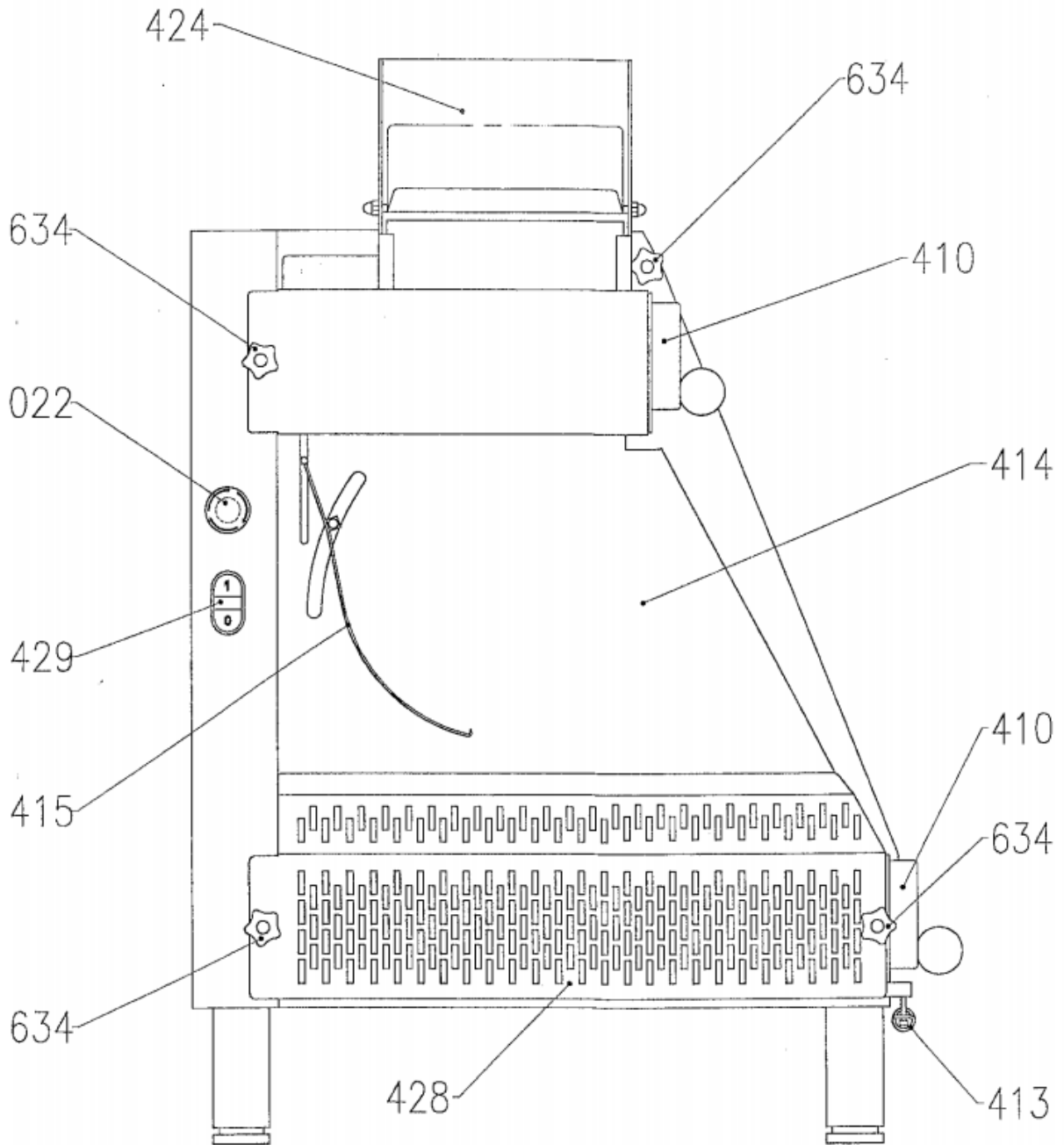

# EXPANDED VIEW M51

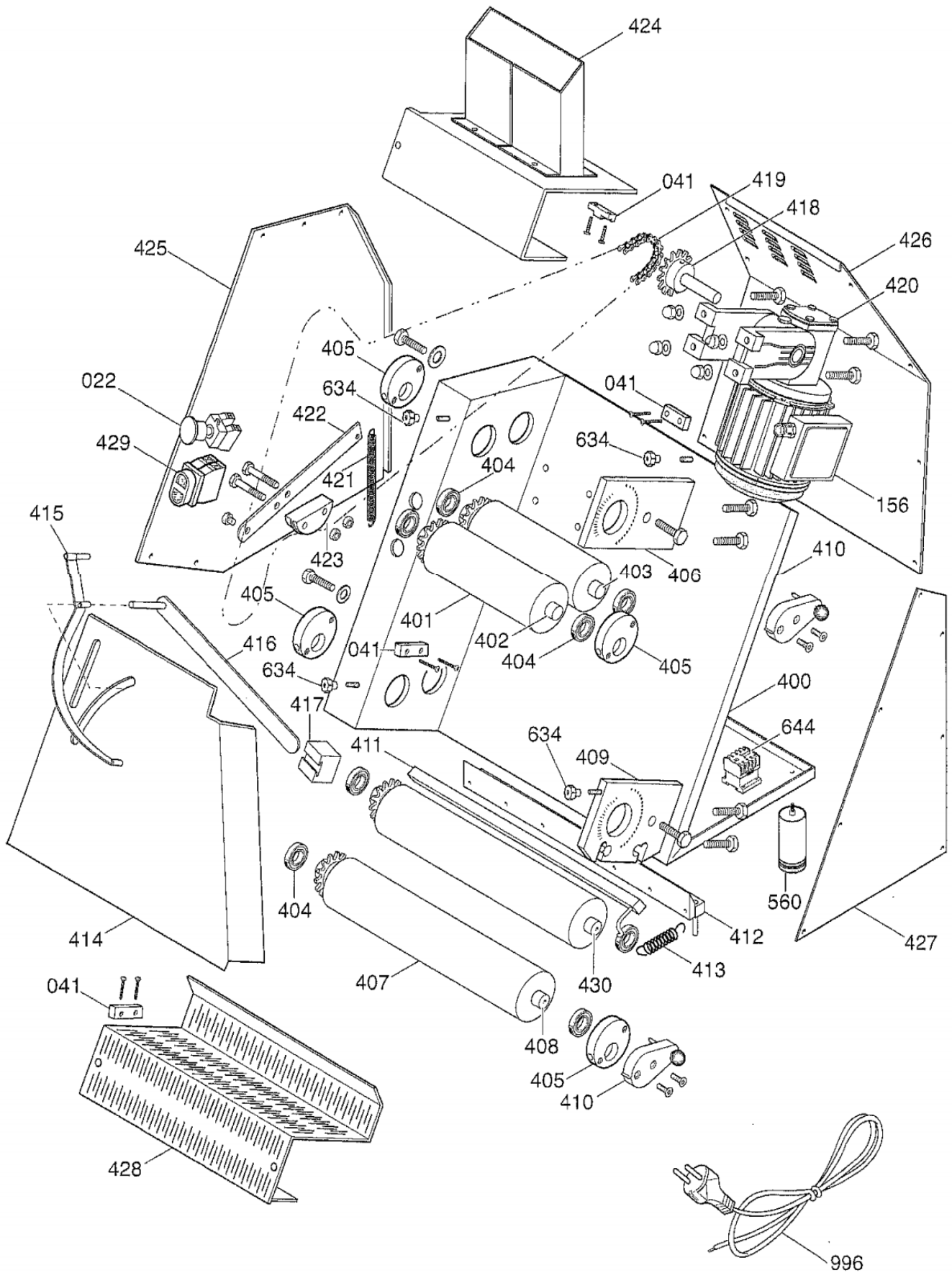



# M33 CIRCUIT SCHEMATICS

