

GIARDINO SERIES

Modular Refractory Pizza Oven Kits

A Custom Wood-Fired Oven Made Easy



The Forno Bravo Giardino Series makes it easy to install an authentic, custom pizza oven in a small space – at a price a lot lower than you might have thought. Fabricated using the same high quality refractory and insulating materials as commercial pizza ovens and larger residential ovens, the Giardino ovens offer the optimal balance between size/weight and cooking capacity. These wonderful ovens can be quickly assembled, while still allowing a homeowner or builder to create a fully customized stand and enclosure.

Like the popular Forno Bravo Primavera and Andiamo assembled pizza ovens that use the Giardino oven core, the Giardino Series offers the industry's fastest heat-up times (as fast as 20 minutes) and remarkably good heat retention – perfect for pizza making, hearth bread baking, roasting and grilling. Don't let their smaller footprint fool you; the Giardino Series ovens pack a huge amount of wood-fired cooking in a small, affordable package.

GIARDINO SERIES

Modular Refractory Pizza Oven Kits

A Custom Wood-Fired Oven Made Easy

The ovens are available in two sizes: 24" and 28" rounds, with a 6" landing, and include everything you need to assemble a complete oven core, including the oven dome and vent, floor, insulation, chimney, door and thermometer. Building a wood-fired oven has never been so easy.

Like all Forno Bravo ovens, the Giardino Series features four unique technologies:

🐘 The Giardino 1 ½" oven dome is produced using a proprietary 142 pcf density, 8,230 psi strength refractory material and a two-sided, vibrated mold casting process – the same material and process we use for our commercial ovens. It is a remarkably hard and durable material that is superior to old-fashioned clay ovens.

🐘 The Giardino 1 ½" oven floor is constructed using 12"x12"x1 ½" commercial-grade (2,700psi compressed and 2650°F kiln-fired) baking tiles with Cordierite – for superior thermal shock resistance and better baking.

🐘 Each Giardino oven is delivered with complete insulation for outstanding heat retention, and includes 3" of high-tech ceramic blanket dome insulation and 2" of ceramic board floor insulation – eliminating the need for old-fashioned and inefficient vermiculite or Perlite. This is the same volume and quality of insulation that we use in the larger and heavier Casa2G ovens.

🐘 The Giardino Series features a monoblock dome with an integral vent, making assembly easy – there are no seams to line up or mortar together.

The Giardino ovens can be installed either on a site-built concrete block stand, or a Forno Bravo metal oven stand. A decorative brick arch and oven tools are available as options.

The Giardino FAMILY

	COOKING SURFACE	AREA (sq. in.)	HEAT UP (min)	PIZZAS (10")	BREAD (lb.)
Giardino60	24" x 29"	425	20	1	8
Giardino70	28" x 33"	615	30	2	12

GIARDINO SERIES

Modular Refractory Pizza Oven Kits

A Custom Wood-Fired Oven Made Easy

Giardino Series AT-A-GLANCE

	GIARDINO60	GIARDINO70
Internal Dimensions	24"W x 29"D	28"W x 33"D
External Dimensions	27"W x 30.5"D x 15"H	31"W x 34.5"D x 15"H
Oven Opening	16"W x 9.5"H	16"W x 9.5"H
Vent Landing	17"W x 5"D	17"W x 5"D
Dome Height	14"	14"
Dome Thickness	1 1/2"	1 1/2"
Floor Thickness	1 1/2"	1 1/2"
Ceramic Blanket Dome Insulation	3 x 1"	3 x 1"
Ceramic Board Floor Insulation	1 x 2"	1 x 2"
Steel Door and Thermometer	Single Wall	Single Wall
Stainless Steel Chimney, Anchor Plate and Rain Cap	12" x 5"	12" x 5"
High Temp., Waterproof Mortar	25 lb.	25 lb.
Weight (Dome, Floor and Vent)	400 lb.	475 lb.

Distributed By:

Pizza Equipment Professionals

Phone: (800) 655-1831

Fax: (209) 824-4684

www.PizzaEquipmentPros.com

info@pizzaequipmentpros.com

GIARDINO SERIES

Modular Refractory Pizza Oven Kits

A Custom Wood-Fired Oven Made Easy

Giardino Series ADVANTAGES

1. MONOBLOCK DOME

Single piece oven dome for easier assembly and better heat retention.

2. DOME INSULATION

3 x 1" ceramic dome insulation for easy assembly and outstanding heat retention.

3. REFRACTORY CASTING

1 1/2" thick, 142 pcf, 8,230 psi strength, two-side vibrated form refractory dome for faster heat up and excellent durability.

4. COOKING FLOOR

Compressed (2,700psi), kiln fired (2,650°F) 12"x12"x1 1/2" floor tiles have fewer seams, are more durable, and bake perfect Pizza Napoletana.

5. FLOOR INSULATION

1 x 2" ceramic board floor insulation for easy assembly and excellent heat retention.

6. ENCLOSED COOKING FLOOR

The dome wraps around the floor for better thermal performance.

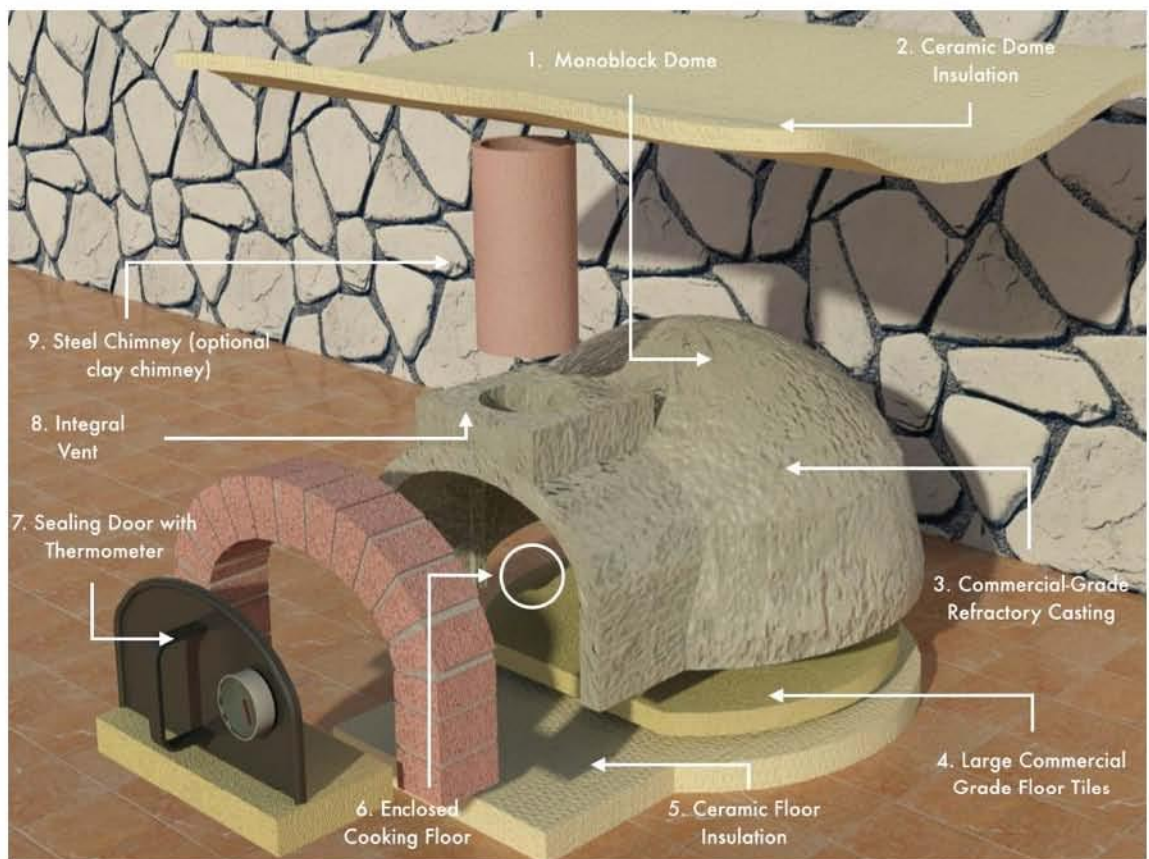

7. SEALING OVEN DOOR

Door seals cooking chamber off from the vent; excellent heat retention.

8. MONOBLOCK VENT

Integral vent for excellent draw, easy installation and outstanding durability.

9. STAINLESS STEEL CHIMNEY

5 x 12" stainless steel chimney, anchor plate, and rain cap; no extra expense or extra shopping. Optional UL103HT ventilation, or clay chimney pipe.

10. PLUS

High temperature, waterproof refractory mortar; no extra shopping or shipping costs.

Distributed By:

Pizza Equipment Professionals

Phone: (800) 655-1831

Fax: (209) 824-4684

www.PizzaEquipmentPros.com

info@pizzaequipmentpros.com

GIARDINO SERIES

Modular Refractory Pizza Oven Kits

A Custom Wood-Fired Oven Made Easy

Giardino Series COMPARISON

	PREMIO2G SERIES	CASA2G SERIES	GIARDINO SERIES
Sizes – Internal Diameter	40", 44", 48"	32", 36", 40", 44"	24", 28"
Dome Thickness	3"	2"	1.5"
Floor Thickness	2"	2"	1.5"
Ceramic Blanket Dome Insulation	4"	3"	3"
Ceramic Board Floor Insulation	3"	2"	2"
Steel Door and Thermometer	Double Wall, Insulated	Single Wall	Single Wall
Stainless Steel Chimney, Anchor Plate and Rain Cap	24" x 8"	24" x 6", 24" x 8"	12" x 5"
Vent Opening Diameter	8"	6", 8"	5"

Distributed By:

Pizza Equipment Professionals

Phone: (800) 655-1831

Fax: (209) 824-4684

www.PizzaEquipmentPros.com

info@pizzaequipmentpros.com

GIARDINO SERIES

Modular Refractory Pizza Oven Kits

A Custom Wood-Fired Oven Made Easy

Giardino Series WHICH SIZE?

Giardino60

Our smallest wood oven, the Giardino can bake one pizza at a time. It can also bake eight loaves of bread, or two small roasting pans. If you are looking for the fun of authentic wood-fired cooking, but you have limited space and budget, the Giardino60 is for you. There is nothing else like it.

- ✿ 24" round cooking surface
- ✿ 6" deep oven landing for staging and warming food
- ✿ 1 pizzas (10")
- ✿ 8 loaves of bread (1 lb.)
- ✿ One chicken
- ✿ 2 smaller roasting pans

Giardino70

The Giardino70 offers 36% more cooking space than the Giardino60—which is a lot of cooking space in a smaller oven. The Giardino70 has room for two personal pizzas at a time, and it simply holds more of everything, including bread, roasts and baking roasting pans.

- ✿ 28" round cooking surface
- ✿ 6" deep oven landing for staging and warming food
- ✿ 2 pizzas (10")
- ✿ 12 loaves of bread (1 lb.)
- ✿ One large chicken
- ✿ 2 roasting pans

GIARDINO SERIES

Modular Refractory Pizza Oven Kits

A Custom Wood-Fired Oven Made Easy

Giardino60 DIMENSIONS

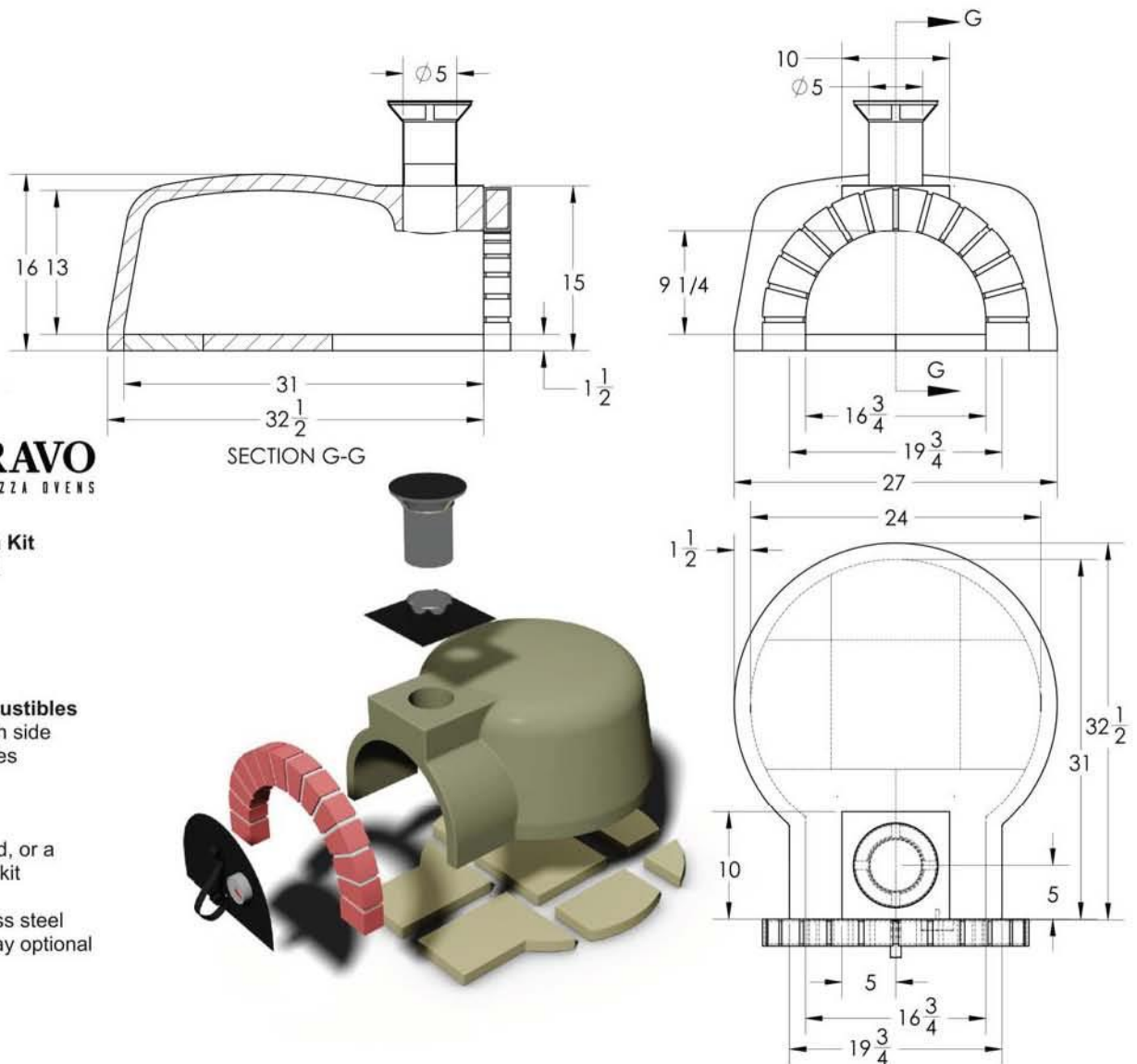

FORNO BRAVO
THE WORLD'S FINEST PIZZA OVENS

Giardion60
24" Modular Pizza Oven Kit
v2.0 © Forno Bravo 2014
251 W. Market St.
Salinas, CA 93901
(800) 407-5110
www.fornobravo.com

Clearances From Combustibles

1" from top; 14" from each side
6" from oven opening sides

Fuel

Wood only

Installation

On a concrete block stand, or a
Forno Bravo metal stand kit

Ventilation

12"x5" single wall stainless steel
standard; UL103HT or clay optional

Brick Arch

Optional

Distributed By:

Pizza Equipment Professionals

Phone: (800) 655-1831

Fax: (209) 824-4684

www.PizzaEquipmentPros.com

info@pizzaequipmentpros.com

GIARDINO SERIES

Modular Refractory Pizza Oven Kits

A Custom Wood-Fired Oven Made Easy

Giardino70 DIMENSIONS

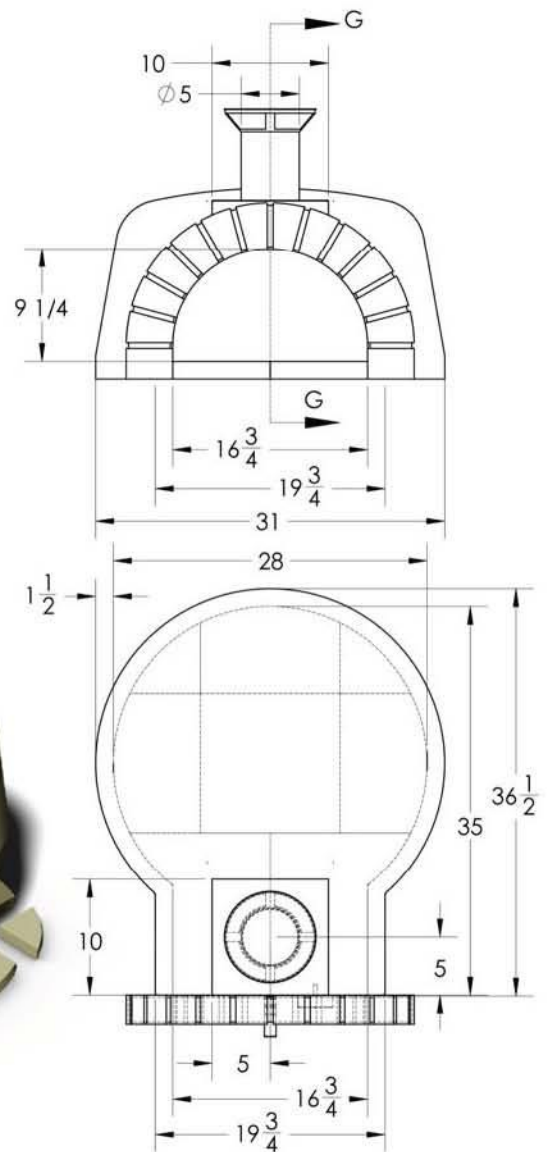
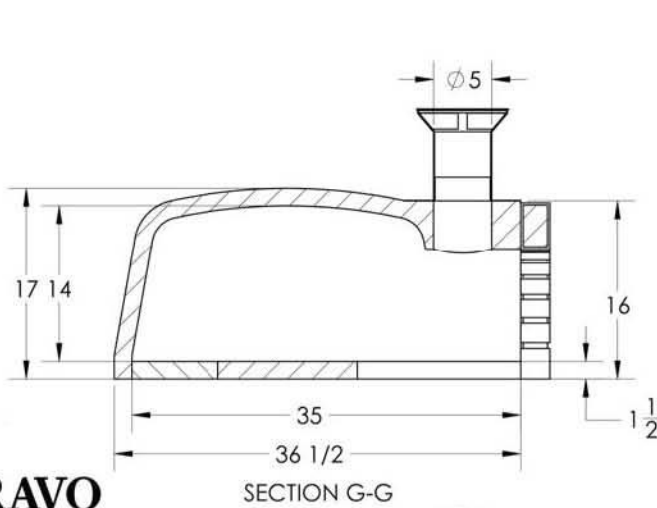

FORNO BRAVO
THE WORLD'S FINEST PIZZA OVENS

Giardino70
24" Modular Pizza Oven Kit
v2.0 © Forno Bravo 2014
251 W. Market St.
Salinas, CA 93901
(800) 407-5110
www.fornobravo.com

Clearances From Combustibles

1" from top; 14" from each side
6" from oven opening sides

Fuel

Wood only

Installation

On a concrete block stand, or a Forno Bravo metal stand kit

Ventilation

12"x5" single wall stainless steel standard; UL103HT or clay optional

Brick Arch

Optional

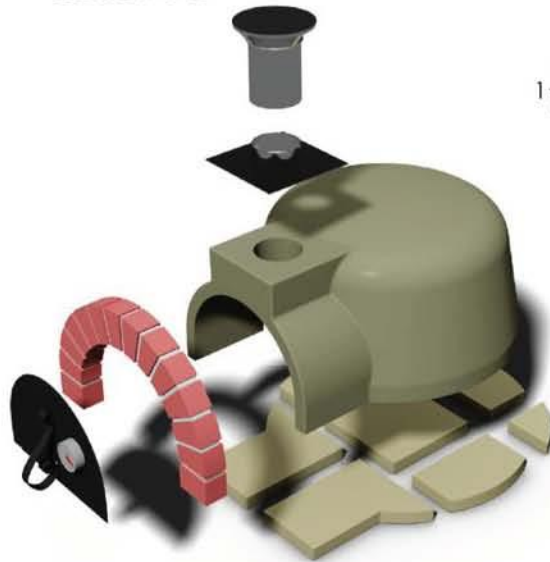

Distributed By:

Pizza Equipment Professionals

Phone: (800) 655-1831

Fax: (209) 824-4684

www.PizzaEquipmentPros.com

info@pizzaequipmentpros.com

FORNO BRAVO
THE WORLD'S FINEST PIZZA OVENS